

55" 3D 4K Medical Display

FM-A5505DGC



- *OLED technology. High contrast ratio. Perfect blacks.*
- *Reduced blue light emission and eye fatigue.*
- *Immersive 3D viewing is ideally suited for large screens.*



More Surface Textures More Depth of Field

FM-A5505DGC, the 55" 3D display monitor from FSN, delivers OLED technology for true blacks, better contrast, power efficiency, and lighter weight. The immersive viewing experience of 3D is ideally suited for a large screen of this size.

FM-A5505DGC is compatible with highly specialized visualization equipment used in operating rooms and surgical suites. It is suitable for showing multiple images at sizes big enough to remain visible across the operating room. Picture quality is crystal clear, and the user interface allows for complete control of image color and multi-window layouts.



3D eye wear included.

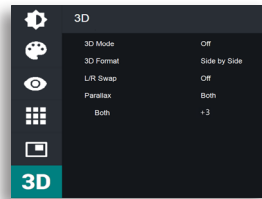

Complete Control

A detailed 3D menu offers control for the best possible image format. Side By Side, Line By Line, Top Bottom, SDI level B-DS, SDI Dual Input.

FSN's attention to engineering details, such as rounded bezel corners, backlit touch buttons, and easy to use interface menu controls, allow for safe and efficient interaction. This large screen delivers everything that professionals need in a 3D, 4K UHD medical-grade monitor.

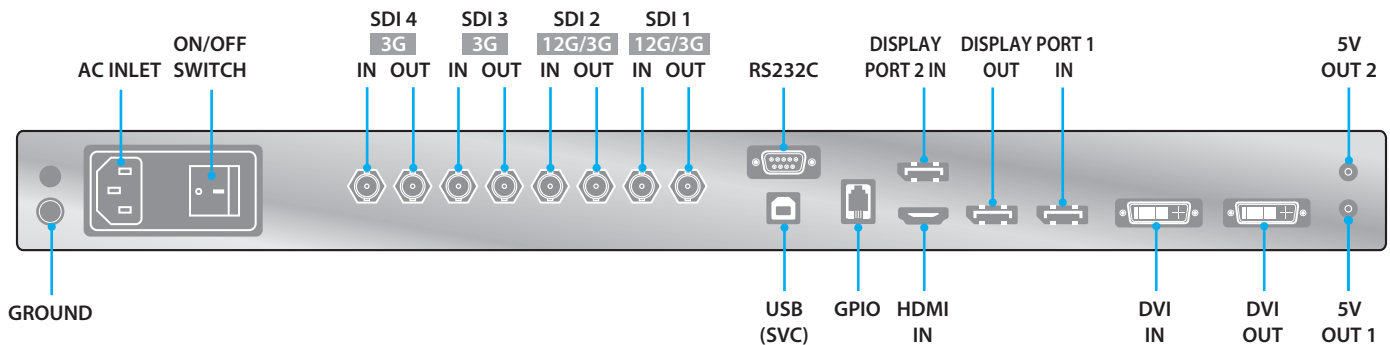

www.fsnmed.com

Foreseeson Custom Displays, Inc.
2210 E. Winston Road
Anaheim, CA 92806 USA
Tel: 714-300-0540
Fax: 714-300-0546

Latin America
Aventura, FL 33180 USA
Tel: 714-507-3855

Foreseeson Korea
404B, PangyoInnovalley B
253 Pangyo-ro
Bundang-gu Seongnam-si
Gyeonggi-do, Korea 463-400
Tel: +82-31-8018-0780
Fax: +82-31-8018-0786

Foreseeson GmbH
Industriestrasse 38a
63150 Heusenstamm, Germany
Tel: +49 6104 64398 0
Fax: +49 6104 64398 11

Foreseeson UK Ltd.
Unit 71 Barwell Business Park
Leatherhead Road
Cheshington, Surrey KT9 2NY
Tel: +44 (0) 208 546 1047

Foreseeson (Shanghai)
Medical Equipment Co., Ltd.
Room 307, 3F
No. 56, 461 Hongcao Road
Caohejing Development District
Xuhui, Shanghai 200233
Tel: 86-21-6113-4188

55" 3D 4K Medical Display

FM-A5505DGC



Specifications

FSN Medical Technologies products meet RoHS2 and Registration, Evaluation, Authorisation and Restriction of Chemicals (REACH) obligations. FSN manages the information flow as required by regulations.

General Features

Item	Description
Panel	55 inch OLED
Resolution	3840 x 2160 pixels
Aspect Ratio	16 : 9
Active Area	1209.60 (H)mm x 680.40 (V)mm
Response Time (typical)	0.5 ms (gray to gray)
Number of Colors	1.07 Billion
Brightness (typical)	(2D) 150 cd/m ² (220 cd/m ² peak) (3D) 90 cd/m ²
Gamut	BT.709 and BT.2020 compatible
Contrast Ratio (typical)	100,000 : 1
Surface Treatment	Anti-glare
Viewing Angle	(2D) R/L 120°, U/D 120° (3D) U/D 8.6°
Input Signal	1 x HDMI (2.0, HDCP 2.2) 2 x DP (1.2 SST) 4 x SDI (3G), 2 x SDI (12G) 1 x DVI (single link, HDMI 1.4, HDCP 1.4)

Item	Description
Output Signal	1 x DP 1.2 (SST) 4 x SDI (3G), 2 x SDI (12G) 1 x DVI (single link, HDMI 1.4, HDCP 1.4)
Power Supply	SMPS (AC 100 ~240V)
Power Consumption	250W max
Accessories Included	User manual, AC power cord, DP cable, HDMI cable, DVI-D cable, BNC cable, Remote control and batteries
Unit Dimension	1268.5(W) x 753.3(H) x 85(D) mm 49.94(W) x 29.66(H) x 3.35(D) inch
Package Dimension	1450(W) x 930(H) x 305(D) mm 57.09(W) x 36.61(H) x 12(D) inch
Weight	29.8 kg, 65.7 lbs. (monitor only) 40.8 kg, 89.95 lbs. (shipping package)
Certifications	ANSI/AAMI ES60601-1(UL60601-1), CAN/CSA C22.2 No. 60601-1, FCC Class B, EN60601-1, EN60601-1-2, CE, MDD(93/42/EEC) Class I Medical Device

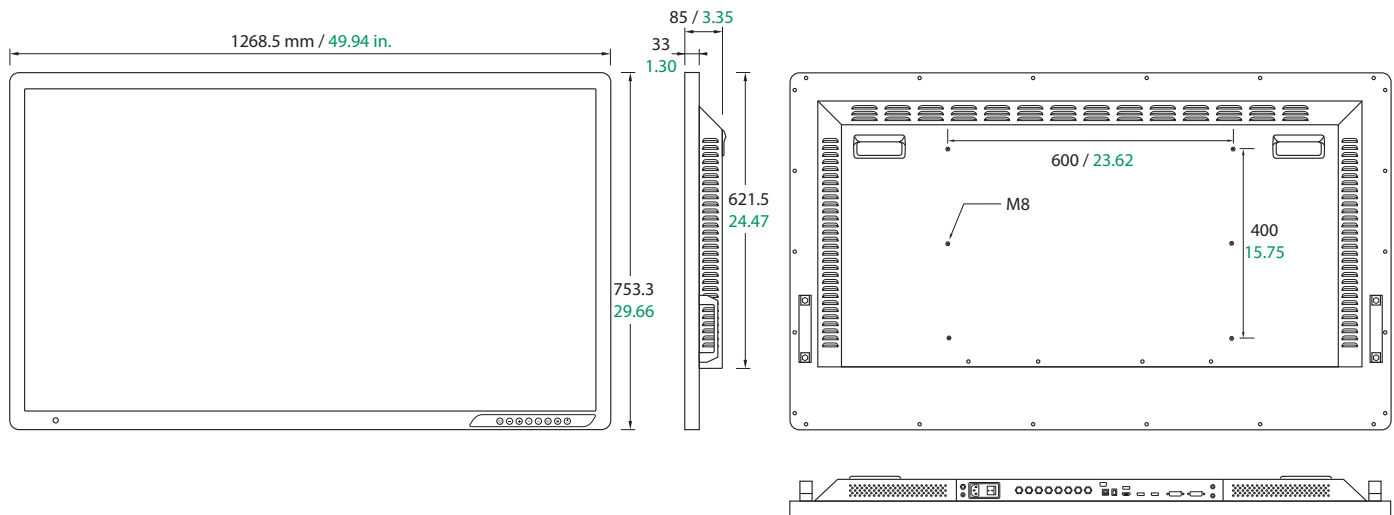

Multiple Windows

There is plenty of room on the FM-A5505DGC monitor for multi-window requirements. Choose from PIP, PBP, Triple, or Quad layouts that are preset and ready-to-go.

Specifications are subject to change with or without notice. Doc.# FSN2032 Rev. 12/20

www.fsnmed.com

Foreseeson Custom Displays, Inc.
2210 E. Winston Road
Anaheim, CA 92806 USA
Tel: 714-300-0540
Fax: 714-300-0546

Latin America
Aventura, FL 33180 USA
Tel: 714-507-3855

Foreseeson Korea
404B, PangyoInnovalley B
253 Pangyo-ro
Bundang-gu Seongnam-si
Gyeonggi-do, Korea 463-400
Tel: +82-31-8018-0780
Fax: +82-31-8018-0786

Foreseeson GmbH
Industriestrasse 38a
63150 Heusenstamm, Germany
Tel: +49 6104 64398 0
Fax: +49 6104 64398 11

Foreseeson UK Ltd.
Unit 71 Barwell Business Park
Leatherhead Road
Chessington, Surrey KT9 2NY
Tel: +44 (0) 208 546 1047

Foreseeson (Shanghai)
Medical Equipment Co., Ltd.
Room 307, 3F
No. 56, 461 Hongcao Road
Caohejing Development District
Xuhui, Shanghai 200233
Tel: 86-21-6113-4188